

# *Owner's Guide*

VISION  FITNESS®

**X6750HRT**

COMMERCIAL INCLINE ELLIPTICAL TRAINER





**C**ongratulations on choosing a VISION FITNESS Incline Elliptical Trainer. You've taken an important step in developing and sustaining an exercise program! Your Incline Elliptical Trainer is a tremendously effective tool for achieving your facility's fitness goals. Regular use of your Incline Elliptical Trainer can improve the quality of your members' lives in so many ways.

Here are just a few of the health benefits of aerobic exercise:

- Weight Loss
- A Healthier Heart
- Improved Muscle Tone
- Increased Daily Energy Levels
- Reduced Stress
- Help in Countering Anxiety and Depression
- An Improved Self Image

The key to reaping these benefits is to develop the exercise habit. Your new Incline Elliptical Trainer will be an important tool in helping your members achieve this exercise habit. This Owner's Guide provides you with basic information on using this VISION FITNESS Incline Elliptical Trainer. A more complete knowledge of your new Incline Elliptical Trainer will assist you in helping your members achieve their goals.

Some kinds of service to your Incline Elliptical Trainer should only be performed by your VISION FITNESS retailer. Please contact your authorized VISION FITNESS retailer should service be required. If a question or problem arises which cannot be handled by your VISION FITNESS retailer, please contact us:

VISION FITNESS  
500 South CP Avenue  
P.O. Box 280  
Lake Mills, WI 53551  
Ph: 1.800.335.4348  
Fax: 1.920.648.3373  
[www.visionfitness.com](http://www.visionfitness.com)

# Table of Contents

ALL MODELS

X6750HRT

GENERAL

## ALL MODELS

SAFETY INSTRUCTIONS	4
ASSEMBLY & MOVING THE INCLINE	
ELLIPTICAL TRAINER	6
STABILIZING THE INCLINE ELLIPTICAL TRAINER, TURNING ON AND OFF	7
CONTACT HEART RATE, INCLINE RAMP	8

## X6750HRT CONSOLE

DISPLAY CONSOLE	10
DISPLAY CONSOLE DESCRIPTIONS	11
SAFE PORTS	13
PROGRAM OVERVIEWS	14
PROGRAM OPTIONS	17
USING THE PROGRAMS	18
USING THE SPRINT 8 PROGRAM	20
USING HEART RATE TRAINING	21
TELEMETRIC HEART RATE	
CHEST STRAP, PLACEMENT	22
ALL HRT PROGRAMS, ADJUSTING	
TARGET HEART RATE	23
USING CUSTOM PROGRAMS	25
ENGINEERING MODE	26

## GENERAL

SERVICE AND TROUBLESHOOTING	
PREVENTATIVE MAINTENANCE	27
TROUBLESHOOTING	28
LIMITED HOME USE WARRANTY	30
COMMERCIAL WARRANTY	32
DEVELOPING A FITNESS PROGRAM	34
EXERCISE GUIDELINES	35
TARGET HEART RATE	36
RATE OF PERCEIVED EXERTION	37
BALANCED FITNESS	38
STRETCHING	39
WEEKLY WORKOUT LOGS	42
MONTHLY WORKOUT LOGS	44



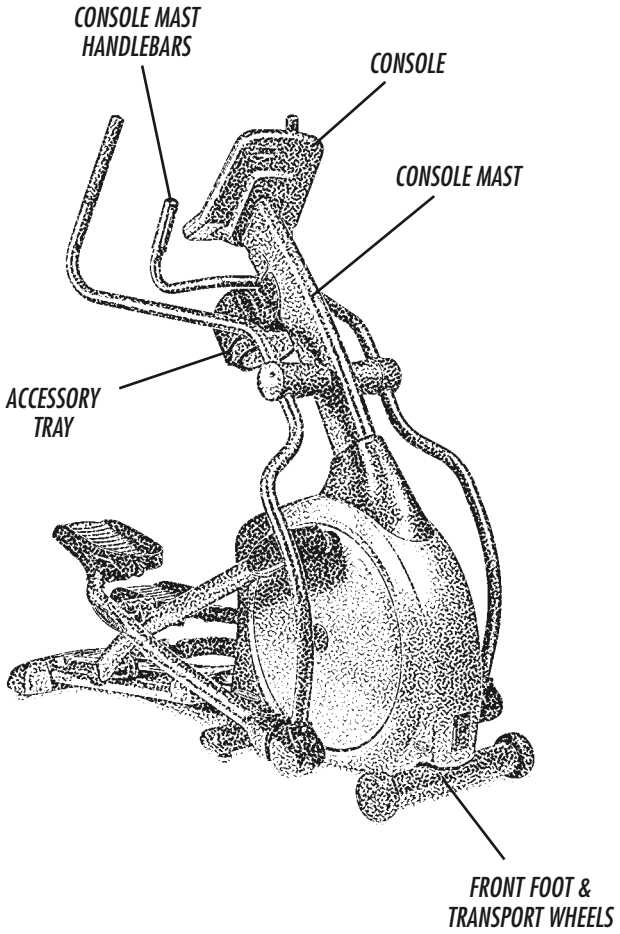

**X6750HRT**

COMMERCIAL INCLINE ELLIPTICAL TRAINER

# IMPORTANT SAFETY INSTRUCTIONS

## SAVE THESE INSTRUCTIONS

When using an electrical product, basic precautions should always be followed, including the following:

Read all instructions before using this exercise product.

**WARNING!** To reduce the risk of burns, fire, electrical shock or injury to persons:

- Use this exercise product for its intended use as described in this Owner's Guide. Only use attachments recommended by the manufacturer.
- Never drop or insert any object into any opening.
- Do not remove the Incline Elliptical Trainer sidecovers. Service should be performed only by an authorized VISION FITNESS retailer.
- Never operate this Incline Elliptical Trainer if it has a damaged cord or plug, if it is not working properly, or if it has been damaged or immersed in water. Please contact your authorized VISION FITNESS retailer for service.
- Keep the cord away from heated surfaces.
- Do not use outdoors.
- To disconnect, turn the switch to the OFF position, then remove plug from outlet.
- Only use the power cord provided with your VISION FITNESS Incline Elliptical Trainer.
- Never place the power cord under carpeting or place any object on top of the power cord that may pinch and damage it.
- Unplug your Incline Elliptical Trainer when not in use and before moving it.

### CHILDREN

- Keep children off your Incline Elliptical Trainer at all times.
- When the Incline Elliptical Trainer is in use, young children and pets should be kept at least 10 feet away.

## OTHER SAFETY TIPS FOR YOUR VISION FITNESS INCLINE ELLIPTICAL TRAINER

**CAUTION!** If you experience chest pains, nausea, dizziness or shortness of breath, stop exercising immediately and consult your physician before continuing.

- Do not wear loose clothing that might catch on any part of the Incline Elliptical Trainer.
- Read this Owner's Guide before operating this Incline Elliptical Trainer.

## CLEANING

- Clean only with soap and a slightly damp cloth; never use solvents.

## ASSEMBLY

It is recommended, when possible, that an authorized VISION FITNESS retailer assemble your Incline Elliptical Trainer. If you have elected to assemble this product yourself, for your safety please read and follow each of the steps in the enclosed assembly instructions. If you have any questions regarding any part or function of your Incline Elliptical Trainer, contact your retailer.

## MOVING

Your VISION FITNESS Incline Elliptical Trainer has transport wheels included for ease of mobility. To move, firmly grasp the rear of the frame assembly. Carefully lift and roll on the transport wheels.

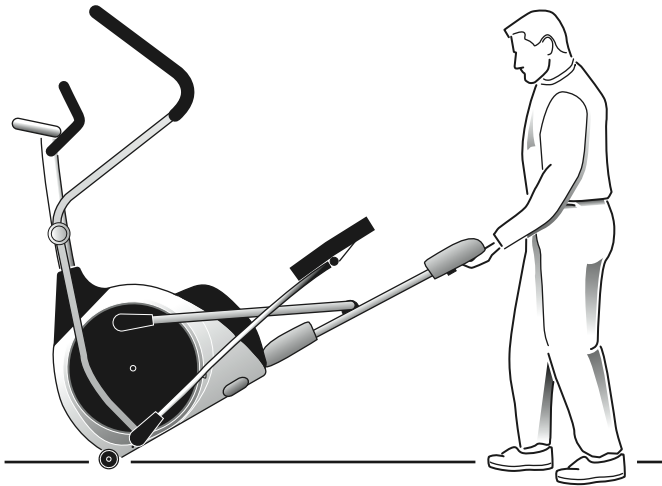

**CAUTION:** Our Incline Elliptical Trainers are well-built and heavy, weighing up to 340 pounds! Use care and additional help if necessary.

## STABILIZING THE INCLINE ELLIPTICAL TRAINER

After positioning the Incline Elliptical Trainer in its intended location, check the unit's stability. Rocking or wobbling indicates that your Incline Elliptical Trainer needs to be leveled. Determine which leveler is not resting completely on the floor. Loosen the nut at the base of the leveler to allow the leveler to rotate. Now rotate the leveler to the left or right until the Incline Elliptical Trainer is stable. Lock the adjustment by tightening the nut against the rear foot support.



## TURNING THE UNIT ON AND OFF

Use the power switch on the front of the unit to turn the machine ON and OFF. It is recommended to turn the machine off when not in use.

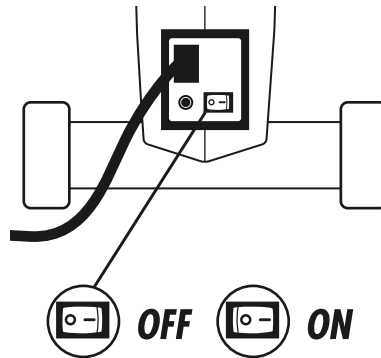

## CONTACT HEART RATE

### HAND PULSE HEART RATE SENSORS

The Contact Hand Pulse Sensors are included on each product to monitor your heart rate. To use, grasp both of the sensors with a comfortable grip during your workout. The console will display your heart rate. It may take the system a few seconds to zero in on your actual heart rate.

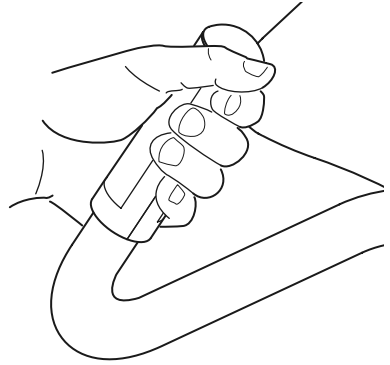

### INCLINE RAMP

Press the INCLINE UP or DOWN arrows to adjust the ramp incline from 1 to 20. This incline setting represents a ramp angle from 4° through 21°.

Ramp changes are not immediate. They will take time to get to the target incline angle.

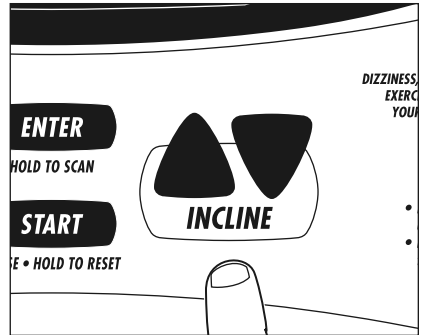



# DISPLAY CONSOLE

## DISPLAY CONSOLE OVERVIEW

The computerized display allows the user to select a workout that meets their desired fitness goals. It also allows the user to monitor the progress and feedback of each workout so they can track improvements in overall fitness over time.

X6750HRT

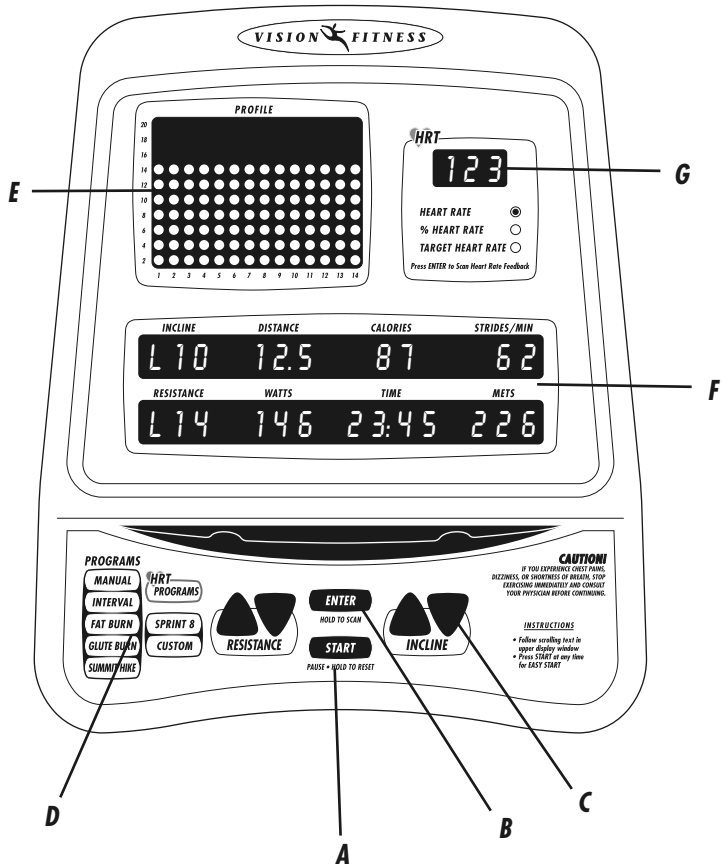

## DISPLAY CONSOLE DESCRIPTIONS

### A. START/HOLD TO RESET

Press the START key to begin a MANUAL workout immediately without having to set individual information. When the program begins, you have the ability to adjust resistance levels with the ARROW keys. Feedback information will be calculated using default settings.

**PAUSE:** If you need to PAUSE your program during a workout, pressing the START key will PAUSE your program for 30 seconds. Pressing START will return you to your workout.

**RESET:** If you need to RESET the console during your workout, you can do so by holding down the START key for three seconds or until the display resets.

### B. ENTER/HOLD TO SCAN

This key is used after entering each piece of information in setup such as age, weight, or level.

**SCAN:** When exercising in a program, pressing the ENTER key will allow you to SCAN the heart rate display views. If you hold down the ENTER key for three seconds during your workout, the SCAN function will automatically alternate heart rate display views.

### C. ARROW KEYS

These keys are used to change values in setup mode prior to your workout. During your workout, they are used to change workout levels. In HRT® programs, they are used to change your target heart rate.

### D. PROGRAM KEYS

These keys provide quick access to your favorite workouts. There is no need to scroll through the programs to find the one you want. Simply press the program key and begin user setup.

## DISPLAY CONSOLE DESCRIPTIONS (continued)

### E. PROFILE DISPLAY

This window provides a dot matrix profile of the workout segments you are about to complete, as well as those you have already completed, and the level of resistance for each segment.

### F. MESSAGE/FEEDBACK WINDOWS

These windows provide step-by-step instructions in the setup mode, instructions, feedback and motivational messages during your workout.

#### FEEDBACK:

During your workout, these windows display exercise feedback about your workout, including:

**TIME:** the time elapsed or the time remaining in your workout.

**DISTANCE:** the total distance traveled in miles or kilometers since the start of your workout.

**STRIDES/MIN:** your stride rate or strides per minute.

**WATTS:** a measurement of workload; one watt is equal to six kilogram-meters per minute.

**CALORIES:** an estimate of calories burned since the beginning of the workout.

**RESISTANCE:** the current resistance level of your workout.

**INCLINE:** the level of ramp incline. There are 20 levels that run between 4° and 21° of elevation.

**METS:** a measurement of oxygen consumption; one MET equals the approximate amount of oxygen consumed per minute by a person at rest.

### G. HEART RATE/HRT FEEDBACK WINDOW

This window provides feedback on your current heart rate and the percent of your predicted maximum heart rate (% Heart Rate). It also includes your target heart rate when using one of the HRT® programs on the *ZOOHRT* products.

## CSAFE

Two network ports allow the Incline Elliptical Trainer to use a fitness entertainment system, and/or an interactive fitness network such as Fitlinxx®.

**CSAFE:** This connection enables the console to upload the users exercise information to a fitness network data base.

**ENTERTAINMENT:** This feature allows the console to power a third-party receiver for entertainment systems such as Cardio Theater®.

These ports are located on the backside of the console and are enclosed by removable covers.

For more information about CSAFE specifications, please visit their web site at: [www.fitlinxx.com/csafa](http://www.fitlinxx.com/csafa)

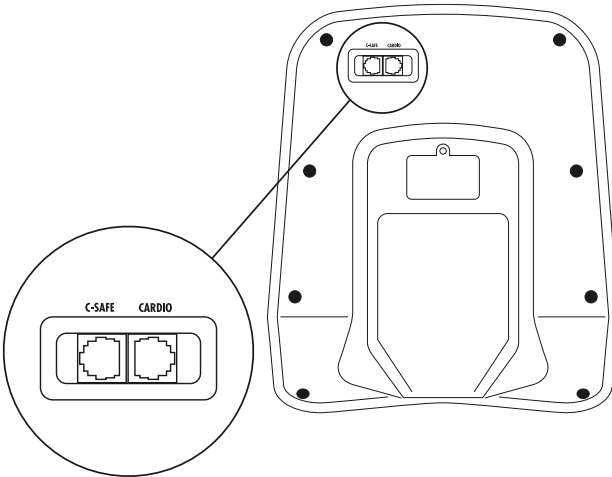

## THE 700HRT SERIES PROGRAMS

### PROGRAM OVERVIEWS

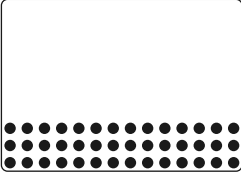

**MANUAL** is a user-controlled program in which the resistance remains at a set level unless you decide to change it.

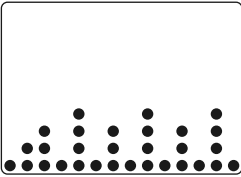

**INTERVAL** is an efficient workout that strengthens your cardiovascular system by alternating work intervals and recovery intervals. Be sure to challenge yourself with intense work intervals.

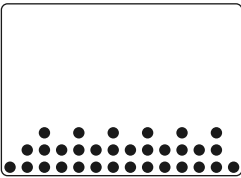

**FAT BURN** is a program designed to target your stored body fat. This program is generally used at a slightly lower resistance level but runs for longer durations than other programs.

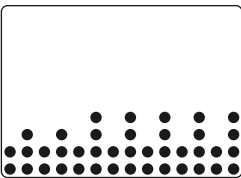

**SPRINT 8** is an anaerobically-based interval program. It is effective in recruiting fast twitch muscle fibers and improving athletic performance.

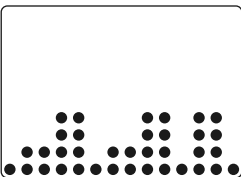

**GLUTE BURN** is a challenging program designed to tone the lower half of the body. The program includes incline changes and user prompts for maximum effectiveness.

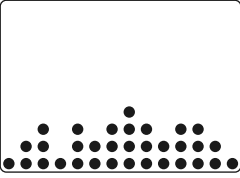

**SUMMIT HIKE** is a variable ramp incline program that adds variety and targets your muscles from different angles.

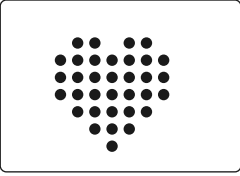

**HRT CARDIO** is a high-intensity program that keeps you at the upper range of your predicted maximum heart rate and promotes cardiovascular endurance and maximum calorie burning. The user must grasp the hand pulse sensors or wear a telemetric heart rate chest strap during use. The program will automatically adjust resistance to keep you at 80% of your predicted maximum heart rate.

**HRT WEIGHT LOSS** is a lower intensity workout that will help your body burn a higher percentage of calories from your body's fat reserves. The user must grasp the hand pulse sensors or wear a telemetric heart rate chest strap during use. The program will automatically adjust resistance to keep you at 65% of your predicted maximum heart rate.

**HRT INTERVAL** alternates between effort intervals of 80% and 70% of your predicted maximum heart rate. This program is designed to increase your cardiovascular fitness capacity. The user must grasp the hand pulse sensors or wear a telemetric heart rate chest strap during use.

**HRT HILL** increases your intensity level from 65% to 70% to 75% to 80% of your predicted maximum heart rate to promote cardiovascular strength and endurance. The user must grasp the hand pulse sensors or wear a telemetric heart rate chest strap during use.



**CUSTOM** allows you to preset up to five workout profiles by setting the workload of each segment in the program. You have the ability to save or change the workouts whenever you wish.

## PROGRAM OPTIONS

<b>PROGRAM</b>	<b>PRESET INCLINE</b>	<b>PRESET RESISTANCE</b>	<b>INSTRUCTIONAL MESSAGE PROMPTS</b>	<b>FIXED TIME</b>	<b>HEART RATE CONTROLLED</b>
MANUAL		•			
INTERVAL		•			
FAT BURN		•			
SPRINT 8		•	•	•	
GLUTE BURN	•				
SUMMIT HIKE	•				
HRT® PROGRAMS		•			•
CUSTOM	•	•			

**NOTE:** The incline profile will be displayed during the GLUTE BURN and SUMMIT HIKE programs. The resistance profile will be displayed briefly if you change your resistance level. All other programs will display the resistance level and only display the inline level briefly when you change the incline level.

## USING THE PROGRAMS

### SELECTING EASY START

The easiest way to begin exercising is to simply press the START key. You will begin exercising in a MANUAL resistance program in which you can change the resistance levels to meet your goals. Current default settings will be used to determine exercise feedback.

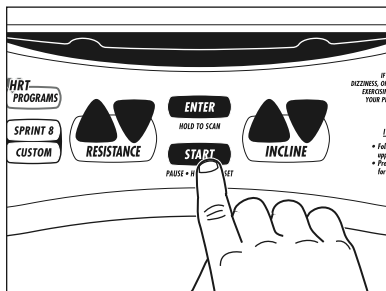

### SELECTING A PROGRAM

Each program has its own program key. Press the key of the program you would like to use. You can also use the arrow keys to scroll through the program options and see the exercise profiles for each of the programs.

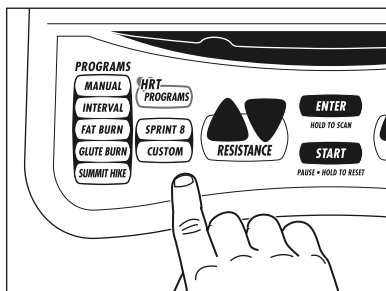

### ENTERING AGE

When prompted by the message center to enter your age, use the UP ▲ arrow or DOWN ▼ arrow to adjust displayed age to the correct value. This information is necessary for the HRT® programs and will affect your "% Heart Rate" feedback.

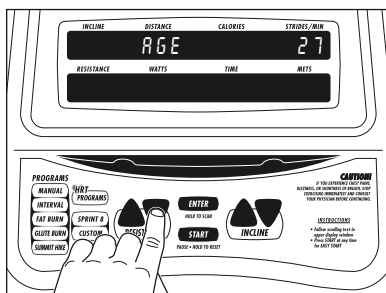

## ENTERING TIME

When prompted by the message center to enter a time, use the UP ▲ arrow and DOWN ▼ arrow to adjust the displayed exercise time to a desired value.

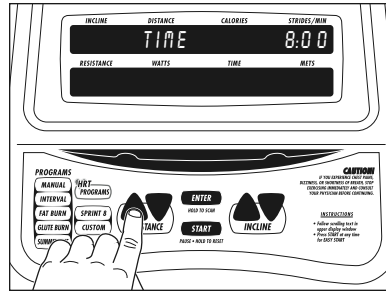

## ENTERING WEIGHT

When prompted by the message center to enter weight, use the UP ▲ arrow and DOWN ▼ arrow to adjust the displayed weight to equal your current body weight. This information is necessary to give accurate exercise feedback for calorie and MET calculations.

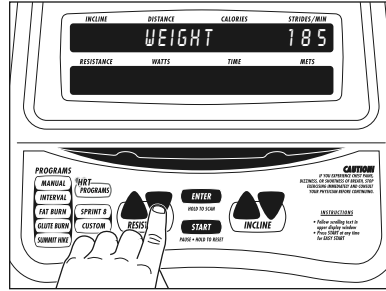

## ENTERING LEVEL

When prompted by the message center to enter level, use the UP ▲ arrow and DOWN ▼ arrow to adjust the displayed resistance level. There are 20 levels of resistance to choose from in each program. The maximum resistance level varies by program.

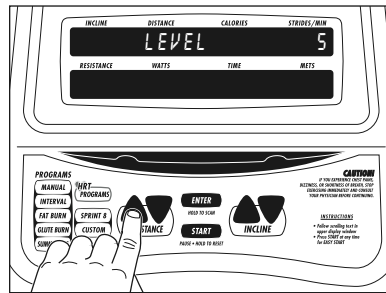

The HRT® programs will set your target heart rate in the place of resistance level. The console will display your target heart rate and give you the opportunity to adjust this value if you wish.

## USING THE SPRINT 8 PROGRAM

The SPRINT 8 program is an anaerobic interval program designed to build muscle, improve speed, and naturally increase the release of Human Growth Hormone (HGH) in your body. Producing HGH through exercise and a proper diet has been shown as an effective way to burn fat and build lean muscle mass according to Phil Campbell, author of *Ready, Set, GO! SYNERGY FITNESS*. Please go to Mr. Campbell's website, [www.readysetgofitness.com](http://www.readysetgofitness.com), for more details about this radical new approach to fitness.

The SPRINT 8 program features intense sprint intervals followed by recovery intervals. The program includes the following phases:

1. **WARM-UP** should gradually increase your heart rate and increase respiration and blood flow to working muscles. The warm-up is controlled by the user to meet your specific needs.
2. **INTERVAL TRAINING** starts immediately after the warm-up with a 30-second sprint interval. Seven recovery intervals of one minute and 30 seconds will alternate with the eight 30-second sprint intervals. The message display will prompt you to increase your stride rate during the sprint interval and decrease stride rate during the recovery interval. A difference of 40 to 60 strides per minute between sprint interval and recovery interval is recommended.
3. **COOL-DOWN** helps return your body's systems to resting levels. Less demand is placed on your heart during recovery if an appropriate cool-down is used following the exercise.

Due to the fact that this is a specialized training program, total workout time is not displayed during the program. The interval time is displayed in the time window instead. It takes only 20 minutes to complete the SPRINT 8 workout.

## USING HEART RATE TRAINING

### WHAT IS HEART RATE TRAINING?

Heart Rate Training means exercising at an intensity that keeps you in your ideal heart rate zone. Your personal heart rate training zone depends on your fitness goal, such as weight loss, cardiovascular endurance, or strength building. Refer to page 36 for more information on heart rate training zones. VISION FITNESS HRT® programs are set up to keep you at an ideal heart rate based on your fitness goal. These programs automatically adjust resistance based on your heart rate readings.

The 700HRT console features four programs (HRT Weight Loss, HRT Cardio, HRT Interval, and HRT Hill) that offer the benefits of Heart Rate Training. Refer to page 23 for more details on these programs.

- *These programs use the predicted maximum heart rate formula (220 minus age) to determine your predicted maximum heart rate. Some individuals have higher or lower maximum heart rates than determined by this formula. The programs allow you to modify your Target Heart Rate to achieve your personal goals.*

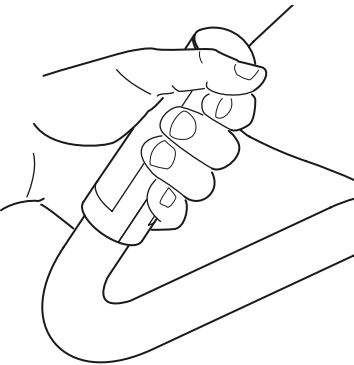

### HAND PULSE HEART RATE SENSORS

The Contact Hand Pulse Sensors are included on each product to monitor your heart rate. To use, grasp both of the sensors with a comfortable grip during your workout. The console will display your heart rate. Although your signal will be displayed immediately, it may take the system a few seconds to zero in on your actual heart rate.

**NOTE:** The Contact Hand Pulse Sensors will work for the HRT® programs, but it is recommended to use the telemetric chest strap for an uninterrupted signal and ease of use.

## TELEMETRIC HEART RATE CHEST STRAP

The wireless Telemetric Chest Strap uses a pair of electrodes on the underside of the strap to send your heart rate signal to the console. Prior to wearing the chest strap, moisten the two rubber electrode pads with several drops of water. These electrodes must remain wet to provide an accurate signal. We advise using the chest strap against your skin, but it also functions through a thin layer of wet clothing.

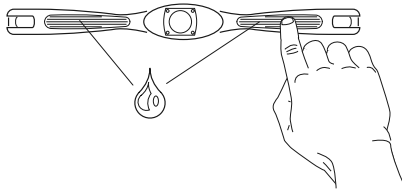

## STRAP PLACEMENT

Center the transmitter strap just below the breast or pectoral muscles, directly over your sternum with the VISION FITNESS logo facing out. Adjust the elastic strap so it is snug but comfortable enough for proper breathing.

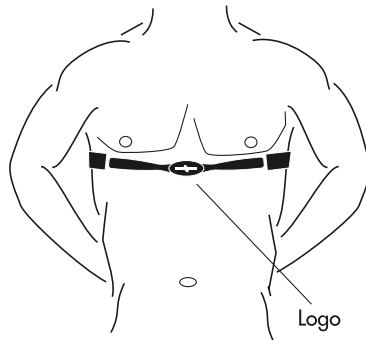



## **HRT CARDIO**

The HRT CARDIO program is designed to maintain your heart rate at 80% of your predicted maximum heart rate. It is intended to improve efficiency and endurance of your cardiovascular system by working your heart, lungs and circulatory systems. This is a great workout for anyone, but beginners may want to start lower and build their way up to 80% of their predicted maximum heart rate.

## **HRT WEIGHT LOSS**

The HRT WEIGHT LOSS program is designed to maintain your heart rate at 65% of your predicted maximum heart rate. The goal of this program is to burn calories by using your body's fat reserves as the primary fuel during exercise and to improve the efficiency of your workout by eliminating over-training or under-training. This is a great workout for beginners.

## **HRT INTERVAL**

The HRT INTERVAL program is designed to increase aerobic endurance and your overall fitness level, increase endurance of muscle fibers, and increase the amount of calories burned in your exercise session. This program consists of alternating effort and recovery intervals. The target heart rate for your effort interval will be 80% of your predicted maximum heart rate, while the target heart rate for your recovery intervals will be 70% of your predicted maximum heart rate. The two-minute effort interval begins when you reach your target heart rate for that particular interval.

## **HRT HILL**

The HRT HILL program uses four different target heart rates to build cardiovascular strength and endurance. The resistance will adjust until your heart rate reaches the target heart rate for the four separate hills. The hills will be set at 65%, 70%, 75%, and 80% of your predicted maximum heart rate. The program will keep you at each heart rate level for one minute from the time the target heart rate is reached. The program will repeat the series of hills until the workout time is complete.

## USING CUSTOM PROGRAMS

The CUSTOM programs allow five separate workout choices to be set and then stored for future use.

Setup for the CUSTOM programs begins just as any other program. The user will push the CUSTOM program key, set age, set time, and set weight. At this point, the console will ask the user to select one of five CUSTOM programs. If the programs have not yet been set, the user can follow these setup instructions:

1. Use the arrows to select one of five CUSTOM programs.
2. Press ENTER to select.
3. The dot on the bottom left corner of the dot matrix will now be flashing. Use the UP ▲ or DOWN ▼ arrow to adjust the resistance of the first segment to your desired setting.
4. Push ENTER to select.
5. Continue setting each segment until all 14 segments have been set.
6. When you pressed ENTER after the final segment, you will now have the option of setting your incline levels.
7. Use the UP ▲ or DOWN ▼ arrow to adjust the incline of each segment.
8. Press ENTER to select.
9. Continue setting each segment until all 14 segments have been set.
10. Press START to begin.

Each program will remain saved in the console's memory and can be used over again.

If the CUSTOM programs have already been saved, you have two options:

1. Press START to begin the program as it has been set.
2. Press ENTER to begin resetting each segment for a new program.

## ENGINEERING MODE

Engineering mode consists of 15 different options. Use the engineering mode to change settings on your Incline Elliptical Trainer console.

### ENTERING ENGINEERING MODE

- Press and hold the UP ▲ and DOWN ▼ keys for approximately three seconds.
- The console will beep and display engineering modes and optional settings. Use the UP ▲ or DOWN ▼ keys to scroll through the options. Press the ENTER key to select the appropriate mode or setting.

### OPTIONAL SETTINGS

<b>SETTING</b>	<b>DESCRIPTION</b>
MAX TIME	SET A MAXIMUM WORKOUT TIME
USER TIME	SET A DEFAULT TIME FOR ALL PROGRAMS
DF AGE	SET A DEFAULT AGE FOR ALL PROGRAMS
DF WEIGHT	SET A DEFAULT WEIGHT FOR ALL PROGRAMS
DF LANGUAGE	SET THE LANGUAGE TO ENGLISH, FRENCH, GERMAN, ITALIAN, OR DUTCH
UNIT	SET MILES/LBS. OR KM/KG.
AC TIME	DISPLAY ACCUMULATED HOURS OF USE
AC DIST	DISPLAY ACCUMULATED MILES OR KILOMETERS OF USE
DISPLAY TEST	CHECK FUNCTION OF LED DISPLAY
INC-RST.	TURN INCLINE RESET ON OR OFF
RST TIME	SET TIME OF WORKOUT RESET
INCLINE CAL.	INCLINE CALIBRATION
H-POINT	SET HIGH POINT OF INCLINE
L-POINT	SET LOW POINT OF INCLINE
VERSION	DISPLAY CURRENT SOFTWARE VERSION

- Use the UP ▲ and DOWN ▼ keys within each setting to modify the setting.
- Press the START key to save the setting.
- To EXIT engineering mode, press and hold the START key for three seconds.

## SERVICE AND TROUBLESHOOTING

### PREVENTATIVE MAINTENANCE TIPS

- To reduce the risk of electrical shock always unplug the Incline Elliptical Trainer from the electrical outlet before cleaning or maintaining.
- Locate Incline Elliptical Trainer in a cool, dry place.
- Make sure all bolts and fasteners are kept tight.
- Keep the display console free from fingerprints and salt buildup caused by sweat.
- Use a cotton cloth with water and a mild cleaning product to clean the Incline Elliptical Trainer. Other fabrics, including paper towels, may scratch the surface. Do not use ammonia or acid-based cleaners.
- Clean the housing thoroughly on a regular basis.

### PREVENTATIVE MAINTENANCE SCHEDULE

Follow the schedule below to ensure proper operation of the product.

<b><i>ITEM</i></b>	<b>DAILY</b>	<b>MONTHLY</b>	<b>ANNUALLY</b>
DISPLAY CONSOLE	CLEAN	INSPECT	
ALL BOLTS AND HARDWARE		INSPECT	
FRAME	CLEAN		INSPECT
HANDLEBARS	CLEAN	INSPECT	
GUIDE RAILS	CLEAN		
ROLLER WHEELS	CLEAN	INSPECT	
PLASTIC COVERS	CLEAN		
FOOTPLATES	CLEAN		
POWER CORD		INSPECT	

## TROUBLESHOOTING YOUR INCLINE ELLIPTICAL TRAINER

Our Incline Elliptical Trainers are designed to be reliable and easy to use. If, however, you have a problem, these troubleshooting steps may indicate the cause.

**PROBLEM:** The console does not light up.

**SOLUTION:** Make sure the wire harness is plugged into the back of the console.

**PROBLEM:** The Incline Elliptical Trainer makes a squeaking or creaking noise.

**SOLUTION:** Check and tighten all the bolts on the Incline Elliptical Trainer.

**SOLUTION:** Clean the track and the roller wheels with a cloth and a mild cleaning detergent.

**NOTE:** If the above steps do not remedy the problem, discontinue use, turn the power off and contact your retailer.

### OBTAINING SERVICE

Do not attempt to service this Incline Elliptical Trainer yourself except for the maintenance tasks described in this manual. For information on service to your VISION FITNESS Incline Elliptical Trainer, contact the local retailer from whom you purchased the Incline Elliptical Trainer. To expedite service, please make sure to have your serial number available. The serial number is found on a label located on the front support tube of your Incline Elliptical Trainer.

**SERIAL NUMBER:** \_\_\_\_\_



## LIMITED HOME USE WARRANTY

VISION FITNESS extends the following exclusive, limited warranty, which shall apply only to the use of the device in the home, for residential, non-commercial purposes. Any other use of the device shall void this warranty.

VISION FITNESS hereby extends the following limited warranties for the following components of the device, for the time period indicated:

**FRAME - LIFETIME** VISION FITNESS warrants the Frame against defects in workmanship and materials for the life of the product, so long as it remains in the possession of the original owner.

**CAMBRIDGE MOTOR WORKS™ ELECTROMAGNETIC BRAKE - LIFETIME** VISION FITNESS warrants the Cambridge Motor Works™ Electromagnetic Brake against defects in workmanship and materials for the life of the product, so long as the device remains in the possession of the original owner.

**ELECTRONICS & PARTS - FIVE YEARS** VISION FITNESS warrants the Electronic components and all original Parts against defects in workmanship and materials for a period of five years from the date of purchase, so long as the device remains in the possession of the original owner.

**LABOR - TWO YEARS** VISION FITNESS shall cover the Labor cost for the repair of the device for a period of two years from the date of original purchase, so long as the device remains in the possession of the original owner.

## LIMITED HOME USE WARRANTY (continued)

### EXCLUSIVE REMEDY

The exclusive remedy for any of the above warranties shall be repair or replacement of defective Parts, or the supply of Labor to cure any defect, provided that Labor shall be limited to two years. All Labor shall be supplied by the local Retailer and the product must be located within that Retailer's service area. Products located outside the Retailer's service area will not be covered by the Labor warranty.

### EXCLUSIONS AND LIMITATIONS

This warranty applies only to the original owner and is not transferable. This warranty is expressly limited to the repair or replacement of a defective Frame, Cambridge Motor Works™, Electromagnetic Brake, Electronic component, or defective Part and is the sole remedy of the warranty. The warranty does not cover normal wear and tear, improper assembly or maintenance, or installation of parts or accessories not originally intended or compatible with the Fitness Product as sold. The warranty does not apply to damage or failure due to accident, abuse, corrosion, discoloration of paint or plastic, or neglect. VISION FITNESS shall not be responsible for incidental or consequential damages. Parts and Electronic components reconditioned to As New Condition by VISION FITNESS or its vendors may sometimes be supplied as warranty replacement parts and constitute fulfillment of warranty terms. Any warranty replacement parts shall be warranted for the remainder of the original warranty term.

VISION FITNESS expressly disclaims all other warranties, express or implied, including but not limited to all warranties of fitness for a particular purpose or of merchantability. This warranty gives you specific legal rights, and your rights may vary from state to state.

### WARRANTY REGISTRATION

Your warranty card must be completed and sent to VISION FITNESS before a warranty claim can be processed. You may also register via our website at [www.visionfitness.com](http://www.visionfitness.com). Inside the enclosed warranty card, you will find a customer survey. Your care in completing the survey will be of value to us in serving you in the future. Comments and suggestions are always welcome. We are certain you will enjoy your new Incline Elliptical Trainer. Thank you for selecting a VISION FITNESS product.

## COMMERCIAL WARRANTY

**COMMERCIAL USES DEFINED** VISION FITNESS warrants the X6750HRT Incline Elliptical Trainer for use in commercial facilities. Examples of commercial facilities include but are not limited to: Hotels; Resorts; Police and Fire Stations; Apartment Complexes; Rehabilitation and Sports Medicine Clinics; Hospitals; Elementary Middle, and High Schools; YMCAs; Private Health Clubs; Colleges and Universities.

**FRAME - LIFETIME** VISION FITNESS warrants the Frame against defects in workmanship and materials for the lifetime of the original owner, so long as the device remains in the possession of the original owner.

**CAMBRIDGE MOTOR WORKS™ ELECTROMAGNETIC BRAKE, ELECTRONICS, & PARTS - FIVE YEARS** VISION FITNESS warrants the Electromagnetic Brake, Electronics & Parts against defects in workmanship and materials for a period of five years from date of original purchase, so long as the device remains in the possession of the original owner.

**LABOR - TWO YEARS** For a period of two years from the date of purchase, VISION FITNESS, through its local retailers, will provide the necessary Labor for repair and replacement of Frames, Electronics, Motors, and Parts under this warranty, so long as the device remains in the possession of the original owner.

## **COMMERCIAL WARRANTY** (continued)

### **EXCLUSIVE REMEDY**

The exclusive remedy for any of the above warranties shall be repair or replacement of defective Parts or the supply of Labor to cure any defect, provided that the Labor be limited to one year.

### **EXCLUSIONS AND LIMITATIONS**

This warranty applies only to the original owner and is not transferable. This warranty is expressly limited to the repair or replacement of a defective Frame, Electronic component, or defective Part and is the sole remedy of the warranty. The warranty does not cover normal wear and tear, improper assembly or maintenance, or installation of parts or accessories not originally intended or compatible with the product as sold. This warranty does not apply to damage or failure due to accident, abuse, corrosion, discoloration of paint or plastic or neglect. VISION FITNESS shall not be responsible for incidental or consequential damages. Parts and Electronic components reconditioned to As New Condition by VISION FITNESS or its vendors may sometimes be supplied as warranty replacement parts and constitute fulfillment of warranty terms. Any warranty replacement parts shall be warranted for the remainder of the original warranty term.

VISION FITNESS expressly disclaims all other warranties, express or implied, including but not limited to all warranties of fitness for a particular purpose or of merchantability. This warranty gives you specific rights, and your rights may vary from state to state.

### **WARRANTY REGISTRATION**

Your warranty card must be completed and sent to VISION FITNESS before a warranty claim can be processed. We suggest that commercial facilities register via our website at [www.visionfitness.com](http://www.visionfitness.com) and complete the commercial customer survey. Your care in completing the survey will be of value to us in serving you in the future. You may also register by filling out and mailing in the enclosed warranty card. Comments and suggestions are always welcome. We are certain you will enjoy your new Incline Elliptical Trainer. Thank you for selecting a VISION FITNESS product.

## DEVELOPING A FITNESS PROGRAM

By purchasing this piece of VISION FITNESS exercise equipment, you have made a commitment to exercise and now have the convenience of exercising in your own home. Your new equipment offers the flexibility to exercise at whatever time suits you best. It will be easier to maintain a consistent exercise program that will help you achieve your fitness goals.

### ACHIEVING YOUR FITNESS GOALS

An important step in developing a long-term fitness program is to determine your goals. Is your primary goal to lose weight? Improve muscle tone? Relieve stress? Prepare for the spring racing schedule? Knowing what your goals are will help you develop a more successful exercise program. If possible, try to define your personal goals in precise, measurable terms over specific periods of time. Examples of these goals might include:

- Decrease your waistline by two inches over the next two months.
- Run the local 5K race this summer.
- Get 30 minutes of cardiovascular exercise at least five days per week.
- Improve your race time by two minutes over the next year.
- Move from walking a mile to jogging a mile within the next three months.

The more specific the goal, the easier it will be to track your progress. If your goals are long-term, divide them into monthly and weekly segments. Long-term goals can lose some of the motivational benefits. Short-term goals are easier to achieve and will allow you to see the progress you are making. Every time you reach a goal, it is important to set a new goal. This will lead to a healthier lifestyle and will provide the motivation that you will need to move forward.

### TRACK YOUR PROGRESS

Now that you have set your exercise goals, it is time to write them down and make an exercise schedule that will help you achieve them. By keeping a fitness diary, you will stay motivated and know where you are in terms of reaching your goals. As time goes on, you will be able to look back with pride to see how far you've come. For your convenience, we have included exercise log sheets at the end of this manual.

## EXERCISE GUIDELINES

### EXERCISE DURATION

A common question asked is, “how much exercise do I need?” We recommend following the guidelines set up by the American College of Sports Medicine (ACSM) for healthy aerobic activity.

- Exercise three to five days per week.
- Warm up for five to 10 minutes before aerobic activity.
- Maintain your exercise activity for 30 to 45 minutes.
- Gradually decrease the intensity of your workout, then stretch to cool down during the last five to 10 minutes.

If weight loss is a major goal, participate in your aerobic activity at least 30 minutes for five days each week.

### EXERCISE INTENSITY

The next question asked is, “how hard do I need to work out?” To reap the most cardiovascular benefits from your workout, it is necessary to exercise within a recommended intensity range. We recommend using one of two methods to measure exercise intensity. These two methods are performed by monitoring your exercise heart rate or by using the Rate of Perceived Exertion (RPE).

## TARGET HEART RATE

Target Heart Rate is a percentage of your maximum heart rate. Target Heart Rate will vary for each individual depending on age, current level of conditioning, and personal fitness goals. Exercise heart rate should range from 55% to 85% of your maximum heart rate. As a point of reference, we use the predicted maximum heart rate formula of (220 minus age) to determine your heart rate training zone. Please use the following chart to determine your predicted Target Heart Rate.

TARGET HEART RATE ZONES										
Beats Per Minute 										
85%	178	170	161	153	144	136	127	119	110	102
75%	157	150	142	135	127	120	112	105	97	90
65%	136	130	123	117	110	104	97	91	84	78
55%	115	110	104	99	93	88	82	77	71	66
Percentage of Maximum Heart Rate										
AGE	10	20	30	40	50	60	70	80	90	100

### EXAMPLE:

If you are a 30-year-old, your predicted maximum heart rate is 190 based on the (220 minus age) formula.

$$220 - 30 = 190$$

Based on the chart above, your heart rate training zone is 104 to 161, which is 55%–85% of 190.

## RATE OF PERCEIVED EXERTION

Rate of Perceived Exertion (RPE) is one of the easiest ways to monitor exercise intensity. By becoming familiar with the RPE scale, you can continually assess your level of intensity and insure a level of exertion that is comfortable. An increase in exercise intensity is directly related to elevation in exercise heart rate. Consequently, RPE can be used alone or together with heart rate when monitoring exercise intensity.

### RPE SCALE

0	Nothing at all
.5	Very, very weak
1	Very weak
2	Weak
3	Moderate
4	Somewhat strong
5	Strong
6	
7	Very strong
8	
9	
10	Very, very, strong
	Maximal

The recommended RPE range during exercise for most people is between 3 (moderate) and 5 (strong). The RPE should be independent of your pace.

## BALANCED FITNESS

While cardiovascular exercise has been the primary method of fitness for many programs over the years, it should not be the only method. Strength Training and Flexibility Training have become more popular as exercise has developed. Incorporating Strength and Flexibility Training into your current exercise program will give you the balance you need to improve your athletic performance, reduce susceptibility to injury, increase metabolic rate, increase bone density, and reach your goals faster.

## STRENGTH TRAINING

Strength Training was once known as an activity performed by young males only. That has changed with the advances in scientific research on Strength Training over the last 20 years or so. Research has proven that, after age 30, we begin to lose muscle mass if we do not incorporate Strength Training into our exercise program. With this decrease in muscle mass, our ability to burn calories decreases, our physical ability to do work decreases and our susceptibility to injuries increases. The good news is that, with a proper Strength Training program, we can maintain or even build muscle as we age. A proper Strength Training program will work the muscle groups of the upper and lower body. There are now many options available for Strength Training including: yoga, Pilates, selectorized machines, free weights, stability balls or medicine balls, exercise tubing and body weight exercises, just to name a few.

Recommendations for a minimum Strength Training program include:

**FREQUENCY:** Two to three days per week

**VOLUME:** One to three sets consisting of eight to 12 repetitions

## STRETCHING

Flexibility Training is not associated with fitness as often as cardiovascular exercise or Strength Training, even though it is just as important. A good stretching program will help to maintain flexibility of the hips and lower back. A flexible person will be less likely to injure themselves in common activities, such as reaching, twisting and turning, or in uncommon activities such as the annual softball tournament.

Before stretching, take a few minutes to warm up the muscles because stretching a cold muscle can cause injury. Start your stretch slowly, exhaling as you gently stretch the muscle. Try to hold each stretch 15 to 30 seconds. Don't bounce when you stretch. Holding a stretch offers less chance of injury. Don't strain or push a muscle too far. If it hurts, ease up. Here are a few stretches you can incorporate into your exercise program:

### SEATED TOE TOUCH

Sit on the floor with your legs together and straight out in front of you. Do not lock your knees. Extend your fingers toward your toes, exhaling as you go. Hold for 15 to 30 seconds. Return to the start position, and repeat as necessary.

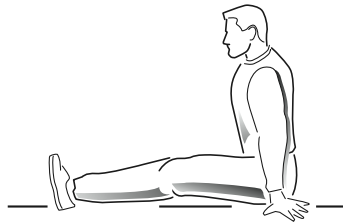

## STANDING QUADRICEPS STRETCH

Using a wall to provide balance, grasp your left ankle with your left hand and hold to stretch. Your knee should be pointing toward the floor. Hold the stretch for 15 to 30 seconds. Repeat with your right leg, and continue to alternate as necessary.

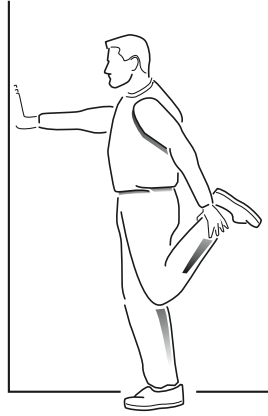

## STANDING CALF STRETCH

Standing about three to four feet from the wall, take one step forward with your right foot. Place your hands on the wall in front of you. Bend your right leg slowly, using your movement to control the amount of stretch in the left calf. Your left heel should remain on the ground. Slowly bring yourself back to the starting position and switch legs. Repeat as necessary.

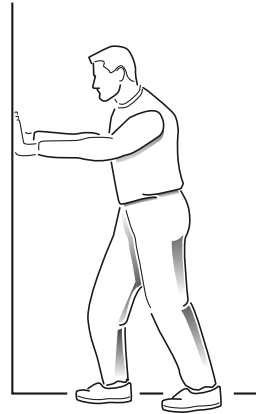



Week #

Weekly Goals: \_\_\_\_\_

Scheduled Workout Time: \_\_\_\_\_

Reward: \_\_\_\_\_

Day	Date	Workload Level	Exercise Time	Distance	Comments
Sunday					
Monday					
Tuesday					
Wednesday					
Thursday					
Friday					
Saturday					
<b>Totals</b>			<input type="text"/>	<input type="text"/>	

Week #

Weekly Goals: \_\_\_\_\_

Scheduled Workout Time: \_\_\_\_\_

Reward: \_\_\_\_\_

Day	Date	Workload Level	Exercise Time	Distance	Comments
Sunday					
Monday					
Tuesday					
Wednesday					
Thursday					
Friday					
Saturday					
<b>Totals</b>			<input type="text"/>	<input type="text"/>	

Week #

Weekly Goals: \_\_\_\_\_

Scheduled Workout Time: \_\_\_\_\_

Reward: \_\_\_\_\_

Day	Date	Workload Level	Exercise Time	Distance	Comments
Sunday					
Monday					
Tuesday					
Wednesday					
Thursday					
Friday					
Saturday					
Totals			<input type="text"/>	<input type="text"/>	

GENERAL

Week #

Weekly Goals: \_\_\_\_\_

Scheduled Workout Time: \_\_\_\_\_

Reward: \_\_\_\_\_

Day	Date	Workload Level	Exercise Time	Distance	Comments
Sunday					
Monday					
Tuesday					
Wednesday					
Thursday					
Friday					
Saturday					
Totals			<input type="text"/>	<input type="text"/>	

**January**

<i>Week</i>	<i>Minutes</i>	<i>Distance</i>
<b>1</b>		
<b>2</b>		
<b>3</b>		
<b>4</b>		
<b>5</b>		
<b>Totals</b>	<input type="text"/>	<input type="text"/>
<b>Reward</b>	_____	

**February**

<i>Week</i>	<i>Minutes</i>	<i>Distance</i>
<b>1</b>		
<b>2</b>		
<b>3</b>		
<b>4</b>		
<b>5</b>		
<b>Totals</b>	<input type="text"/>	<input type="text"/>
<b>Reward</b>	_____	

**March**

<i>Week</i>	<i>Minutes</i>	<i>Distance</i>
<b>1</b>		
<b>2</b>		
<b>3</b>		
<b>4</b>		
<b>5</b>		
<b>Totals</b>	<input type="text"/>	<input type="text"/>
<b>Reward</b>	_____	

**April**

<i>Week</i>	<i>Minutes</i>	<i>Distance</i>
<b>1</b>		
<b>2</b>		
<b>3</b>		
<b>4</b>		
<b>5</b>		
<b>Totals</b>	<input type="text"/>	<input type="text"/>
<b>Reward</b>	_____	

**May**

<i>Week</i>	<i>Minutes</i>	<i>Distance</i>
<b>1</b>		
<b>2</b>		
<b>3</b>		
<b>4</b>		
<b>5</b>		
<b>Totals</b>	<input type="text"/>	<input type="text"/>
<b>Reward</b>	_____	

**June**

<i>Week</i>	<i>Minutes</i>	<i>Distance</i>
<b>1</b>		
<b>2</b>		
<b>3</b>		
<b>4</b>		
<b>5</b>		
<b>Totals</b>	<input type="text"/>	<input type="text"/>
<b>Reward</b>	_____	

**July**

<b>Week</b>	<b>Minutes</b>	<b>Distance</b>
<b>1</b>		
<b>2</b>		
<b>3</b>		
<b>4</b>		
<b>5</b>		
<b>Totals</b>	<input type="text"/>	<input type="text"/>
<b>Reward</b>	<input type="text"/>	

**August**

<b>Week</b>	<b>Minutes</b>	<b>Distance</b>
<b>1</b>		
<b>2</b>		
<b>3</b>		
<b>4</b>		
<b>5</b>		
<b>Totals</b>	<input type="text"/>	<input type="text"/>
<b>Reward</b>	<input type="text"/>	

**September**

<b>Week</b>	<b>Minutes</b>	<b>Distance</b>
<b>1</b>		
<b>2</b>		
<b>3</b>		
<b>4</b>		
<b>5</b>		
<b>Totals</b>	<input type="text"/>	<input type="text"/>
<b>Reward</b>	<input type="text"/>	

**October**

<b>Week</b>	<b>Minutes</b>	<b>Distance</b>
<b>1</b>		
<b>2</b>		
<b>3</b>		
<b>4</b>		
<b>5</b>		
<b>Totals</b>	<input type="text"/>	<input type="text"/>
<b>Reward</b>	<input type="text"/>	

**November**

<b>Week</b>	<b>Minutes</b>	<b>Distance</b>
<b>1</b>		
<b>2</b>		
<b>3</b>		
<b>4</b>		
<b>5</b>		
<b>Totals</b>	<input type="text"/>	<input type="text"/>
<b>Reward</b>	<input type="text"/>	

**December**

<b>Week</b>	<b>Minutes</b>	<b>Distance</b>
<b>1</b>		
<b>2</b>		
<b>3</b>		
<b>4</b>		
<b>5</b>		
<b>Totals</b>	<input type="text"/>	<input type="text"/>
<b>Reward</b>	<input type="text"/>	





*it all  
starts  
with a  
vision*



500 South CP Avenue • P.O. Box 280  
Lake Mills, WI 53551  
toll free 800.335.4348 • phone 920.648.4090  
fax 920.648.3373  
[www.visionfitness.com](http://www.visionfitness.com)

©2006 Vision Fitness. All Rights Reserved.  
HRT is a Trademark of Vision Fitness.  
12.06  
OM18.52PRD  
REV1